

DISCO check valve TYPE RV02



Description:

DISCO-check valves allow the medium to flow just in one direction. If the flow of the medium changes the direction the check valve will close automatically. Available in stainless steel, cast steel and DUPLEX.

Product features:

- Suitable for neutral and not neutral **gaseous and liquid media**
- Short length
- Low opening pressure
- Mounting position: any

Connection

DN15, DN20, DN25, DN32, DN40, DN50, DN65, DN80, DN100, DN125, DN150, DN200, DN250, DN300

Temperature

-196°C to 400°C
- depending on design

Pressure

0,0 bar to 50,0 bar
- see temperature-pressure-rating

Materials: Type RV02

Component	Material RV0200	Material RV0210	Material RV0220
Body	A 351 CF8M	A 216 WCB, zinc plated	A 890 Grade 5A
Disc & Spring cross	A 351 CF8M	A 351 CF8M	A 890 Grade 5A
Spring	AISI 316 Ti	AISI 316 Ti	Hastelloy C4 (2.4610)
NPS	DN15-DN300 / 1/2" – 4"	DN15-DN300 / 1/2" – 4"	DN15-DN300 / 1/2" – 4"

RV0200 – stainless steel

Metallisch	-196°C - +300°C (400°C*)
NBR	-30°C - +100°C
EPDM	-65°C - +150°C
FKM	-30°C - +230°C
PTFE	-196°C - +250°C

RV0210 – steel

Metallisch	-10°C - +300°C (400°C*)
NBR	-10°C - +100°C
EPDM	-10°C - +150°C
FKM	-10°C - +230°C
PTFE	-10°C - +250°C

RV0220 – Duplex

Metallisch	-10°C - +250°C
NBR	-10°C - +100°C
EPDM	-10°C - +150°C
FKM	-10°C - +230°C
PTFE	-10°C - +250°C

Seals apply with the following approvals / conformities:

Seal	Approval
NBR	DIN EN 549, BAM, REACH, RoHS
EPDM	KTW UBA, DVGW W 270, WRAS, NSF, FDA, BfR XXI Kat. 4, ADI-frei, 3A, ASP Cl. 6, BAM, REACH, RoHS
FKM	DIN EN 549, ADI-frei, REACH, RoHS, etc.
PTFE	KTW UBA, DVGW W 270, WRAS, FDA, BfR, ADI-frei, EU 10/2011, 3A, USP Cl. 6, REACH, RoHS

* Temperatures above 300 °C require spring material Hastelloy C4 (low temperature limit for stainless steel: -100 °C). Please contact our sales team.

Up to DN100:

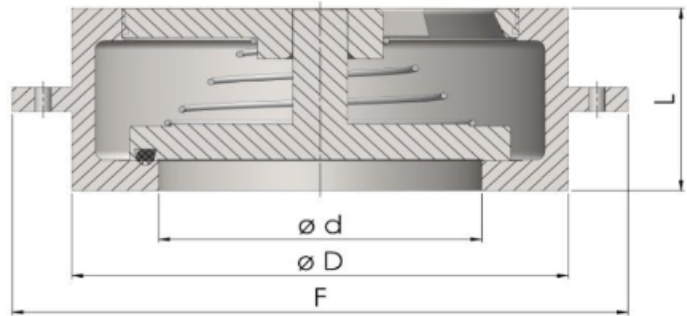

DN	NPS	d	D	F	L
15	1/2"	15	43	57	16
20	3/4"	19	53	72	19
25	1"	25	63	79	22
32	1 1/4"	32	75	92	28
40	1 1/2"	38	80	97	31,5
50	2"	47	95	113	40
65	2 1/2"	63	115	137	46
80	3"	77	131	154	50
100	4"	97,5	150	186	60

Length: DIN EN 558-1 row 49
 Flange acc. to: DIN EN 1092-1 PN6/10/16/25/40 as well as ASME B16.5 ANSI150 / ANSI300

Starting DN125:

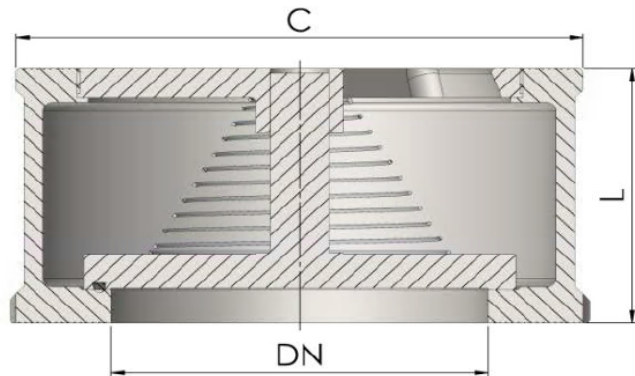
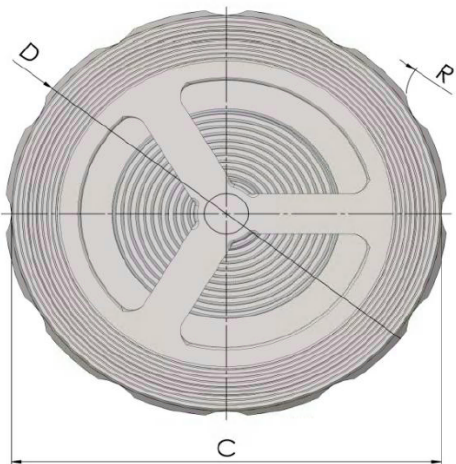

Length: DIN EN 558-1 row 49, starting DN250 acc. to company standard
 Flange acc. to: DIN EN 1092-1 as well as ASME B16.5; PN and ANSI class see table

DN	NPS	C	D	D	C	D	R	R	L	DN
		PN10/16	PN10/16	ANSI150	PN25	PN40	PN10/16	PN25		
125	5"	194	194	194	194	194	-	-	90	118,5
150	6"	220	220	220	220	220	-	-	106	141
200	8"	275	280	280	*)	*)	11	30	140	190
250	10"	331	340	340	*)	*)	13	33	145	229
300	12"	380	386	*)	*)	*)	11	33	160	280

*) Flange PN25/40 or ANSI 150 on request

Installation instructions

Possible damages to the disco check valves and O-rings have to be checked prior to installation. Check if the valve can be moved. Damaged parts must not be installed. Make sure that only those disco check valves are installed, that meet the operational requirements regarding pressure category, chemical resistance, connection and dimensions. Make sure to install a minimum of 5 x nominal diameter of straight pipeline in front of and behind the swing check valve. Do not install the valves directly onto a pump flange. Avoid pulsation and pressure impact. Watch throughput direction (see arrow on the plate)! They are put in their central position according to the outer diameter of the body and the flange screw inner side. Tighten the flange screws crosswise regarding the torque required.

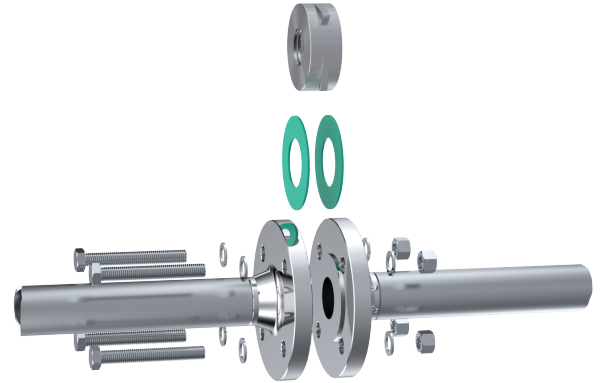
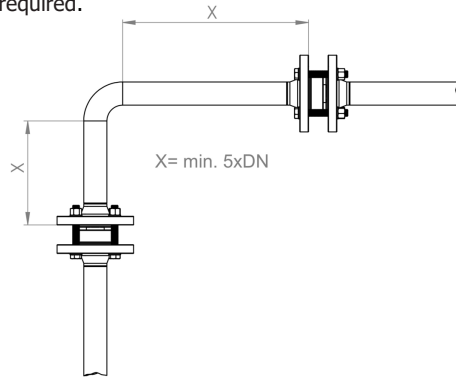

General safety advices

The safety advices for the pipe system, in which the valves are to be mounted, are to be followed. The same applies to the check valves.

In pipe systems, where our check valves are to be used, the planning/installing person and the operator are responsible for the following issues:

- The check valves is to be used according to the regulation in p.1
- The pipe system is to be installed correctly and its operation is to be checked regularly
- The check valves is to be mounted, removed and repaired by qualified personnel only. The staff is to be regularly instructed according to all relevant regulations concerning working safety and environmental protection, especially in the field of pipes under pressure.
- These staff members have to be informed about the manual and the advices included.

Opening pressure

DN SIZE	Kv-value* m3/h	Opening pressure at flow direction in mbar			Weight in kg	
15	1/2"	4	20	16	24	0,12
20	3/4"	7	20	15	25	0,20
25	1"	10	20	15	25	0,32
32	1 1/4"	17	20	14	26	0,52
40	1 1/2"	24	20	13	27	0,62
50	2"	37	20	12	28	1,1
65	2 1/2"	61	20	11	29	1,7
80	3"	74	20	10	30	2,5
100	4"	115	20	7	33	4
125	5"	201	30	14	46	8,4
150	6"	286	30	13	47	12,4
200	8"	553	30	9	51	23,9
250	10"	643	40	16	64	39,2
300	12"	867	40	12	68	58,3

Possible extra-opening pressures in bar – on request*:

0,01	0,02	0,1	0,2	0,3	0,4	0,5	0,7	1	1,5	2	2,5	3
------	------	-----	-----	-----	-----	-----	-----	---	-----	---	-----	---

* The KV-value may be reduced due to usage of disc springs for high extra-opening pressures. Please contact our sales team for more detailed informations.

Pressure-temperature-rating:

Stainless steel:

1.4408	Temperature in (°C)									Pressure (bar)
	-196	20	100	150	200	250	300	350*	400*	
DN15	50	50	50	50	50	46,9	43,8	41,7	40	
DN20	50	50	50	50	48,9	44,5	41,6	39,6	38	
DN25	50	50	50	50	50	46,4	43,4	41,3	39,6	
DN32	50	50	50	50	45,9	41,8	39,1	37,2	35,7	
DN40	50	50	50	50	46,3	42,2	39,4	37,5	36	
DN50	50	50	50	50	45,3	41,2	38,6	36,7	35,2	
DN65	50	50	50	49,1	44,2	40,3	37,7	35,9	34,4	
DN80	50	50	50	49,9	44,9	40,9	38,2	36,4	34,9	
DN100	50	50	50	50	46,7	42,5	39,8	37,9	36,3	
DN125	50	50	50	50	46,4	42,3	39,5	37,6	36,1	
DN150	50	50	50	50	48,3	44	41,2	39,2	37,6	
DN200	50	50	50	44,6	40,1	36,5	34,2	32,5	31,2	
DN250	50	50	50	50	50	46,9	43,8	41,7	40	
DN300	50	50	50	48,7	43,8	39,9	37,3	35,6	34,1	

* Temperatures above 300 °C require spring material Hastelloy C4 (low temperature limit: -100 °C). Please contact our sales team.

Steel:

1.0619	Temperature in (°C)									Pressure (bar)
	-10	20	100	150	200	250	300	350*	400*	
DN15	40	40	35	31,9	29,1	26,5	24,1	22,4	21,6	
DN20	40	40	35,3	32,2	29,4	26,8	24,3	22,6	21,8	
DN25	40	40	40	36,9	33,7	30,7	27,9	25,9	25	
DN32	40	40	38,7	35,2	32,2	29,3	26,6	24,8	23,9	
DN40	40	40	39,8	36,2	33,1	30,2	27,4	25,5	24,5	
DN50	40	40	40	37,5	34,3	31,2	28,4	26,4	25,4	
DN65	40	40	40	38,4	35,1	31,9	29	27	26	
DN80	40	40	40	40	36,6	33,4	30,3	28,2	27,2	
DN100	40	40	40	40	38,6	35,1	31,9	29,7	28,6	
DN125	50	50	49,6	45,2	41,3	37,6	34,2	31,8	30,6	
DN150	50	50	50	50	48,3	44	40,1	37,3	35,9	
DN200	50	50	50	44,6	40,1	36,5	34,2	32,5	31,2	
DN250	50	50	50	50	48,7	44,4	40,4	37,6	36,2	
DN300	50	50	50	48,7	43,8	39,9	37,3	35,6	34,1	

* Temperatures above 300 °C require spring material Hastelloy C4. Please contact our sales team.

Duplex:

1.4469	Temperature in (°C)						Pressure (bar)
	-10	20	100	150	200	250	
DN15	50	50	50	50	50	50	
DN20	50	50	50	50	50	50	
DN25	50	50	50	50	50	50	
DN32	50	50	50	50	50	50	
DN40	50	50	50	50	50	50	
DN50	50	50	50	50	50	50	
DN65	50	50	50	50	50	50	
DN80	50	50	50	50	50	50	
DN100	50	50	50	50	50	50	
DN125	50	50	50	50	50	50	
DN150	50	50	50	50	50	50	
DN200	50	50	50	50	50	50	
DN250	50	50	50	50	50	50	
DN300	50	50	50	50	50	50	

Pressure-loss diagram DN15 – DN100:

The diagram values are valid for water at a temperature of 20 °C and for valves with face-to-face dimensions in accordance with DIN EN 558, suitable for flanges in accordance with PN 10 - PN 40. At the opening of the valve, the curves apply to operation in horizontal pipelines. For calculations for other fluids or temperatures, please contact us.

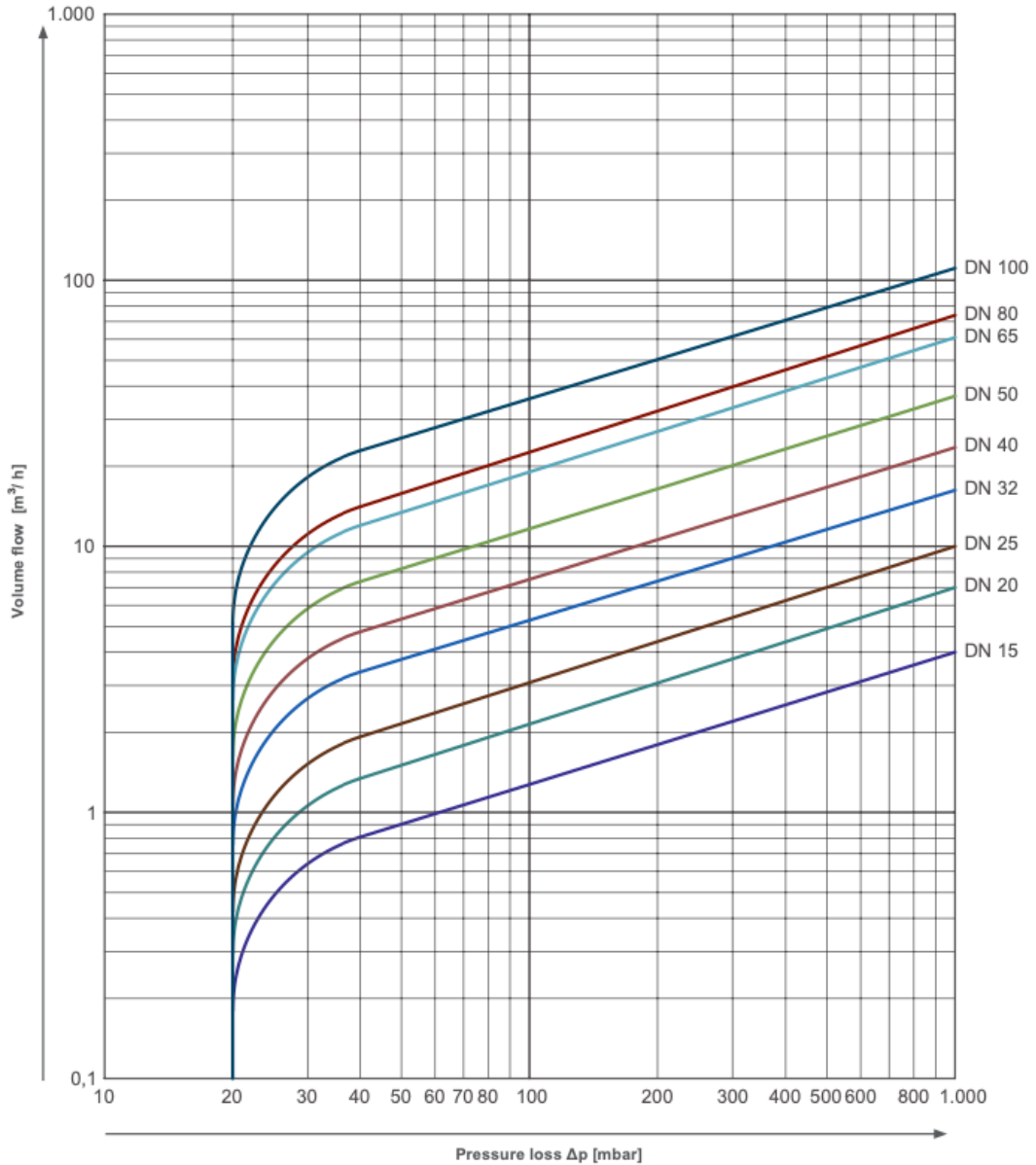

Pressure-loss diagram DN125 – DN300:

The diagram values are valid for water at a temperature of 20 °C and for valves with face-to-face dimensions in accordance with DIN EN 558, suitable for flanges in accordance with PN 10 - PN 40. At the opening of the valve, the curves apply to operation in horizontal pipelines. For calculations for other fluids or temperatures, please contact us.

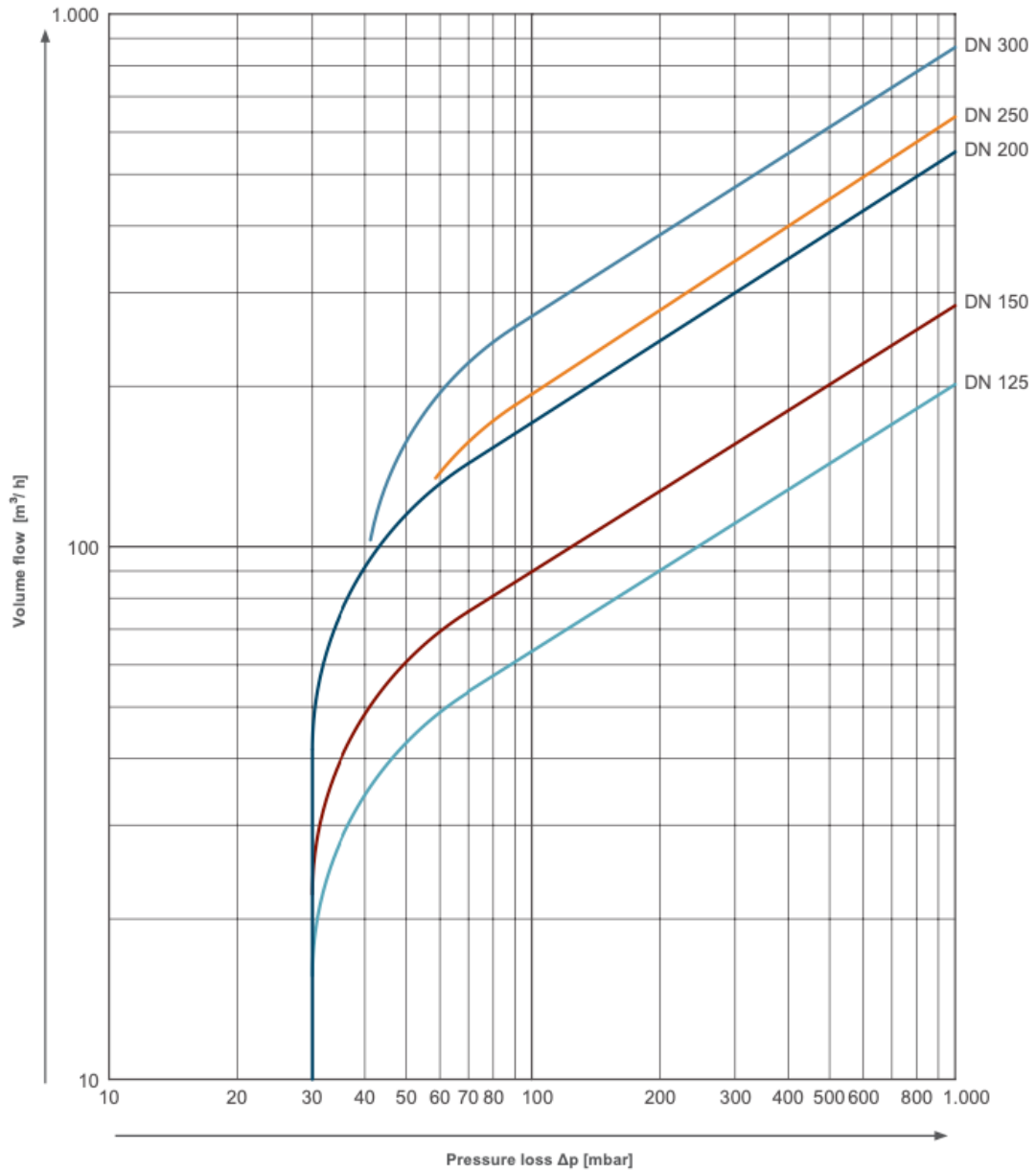

Test meeting the requirement of PED acc. to DIN EN 12266-1:

The tightness corresponds to the specified leakage rates:

Type	Soft seated*	Metal seated
RV02	A	≥ G

* Soft seat: EPDM, FPM/FKM/Viton, NBR

Necessary back pressure for thightness of the check valves:

NBR/EPDM / FKM ➡ 0,3 bar
 PTFE ➡ 1,0 bar

Explosion drawing:

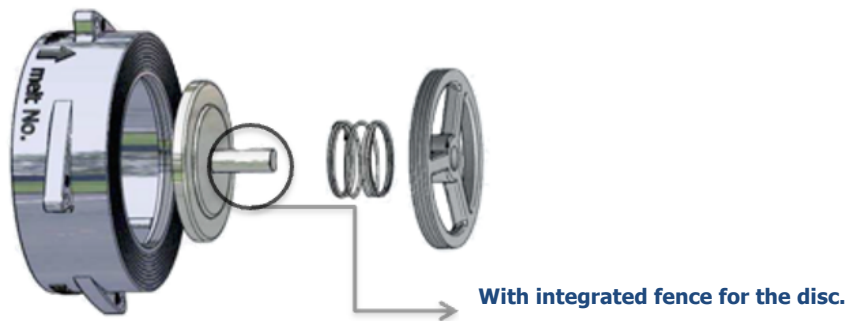

Other special options:

- Special opening pressure (see bottom of page 3)
- Cleaning: cleaned free of oil and grease,
 cleaned free of silicone
 cleaned free of PWIS
- With attached ground cable
- DN150 with D = 226mm (PN25/40)
- Leakage rate D for metal seated valves
- Seals with additional approvals which go beyond the standard
- Seal glued in for vacuum applications (recommended for absolute pressure < 0,1 bar)

Article number:

Type	Material	Seal	Size
RV02 – DISCO check valve PN6-40 – ANSI150/300*	00 – Stainless steel 10 – Steel 20 – DUPLEX	01 – EPDM 02 – FPM 03 – PTFE 04 – NBR 05 – Metal	03 – DN15 04 – DN20 05 – DN25 06 – DN32 07 – DN40 08 – DN50 09 – DN65 10 – DN80 11 – DN100 12 – DN125 13 – DN150 14 – DN200 15 – DN250 16 – DN300

Example **RV02000106:**

RV02 | **00** | **01** | **06**

Article no. RV02000106
DISCO check valve made of stainless steel CF8M
Seal: EPDM
Size: DN32

*) DN125 - DN200: PN10/16/25/40 – ANSI 150
DN200 + DN250: PN10/16 – ANSI 150
Starting DN300: PN10/16

Image similar, subject change without notice.