

Cryo safety-valve TYPE SV14



Description:

Cryo safety valves are used to protect a closed system against overpressure. suitable for cryogenic temperatures.

Features:

- Suitable for neutral liquids as well as cryogenic liquified gases such as: LIN, LOX, LAr, CO₂, LNG.
- Optional with lever
- TUV-type test approval 2091 D/G, F
- EC type examination S/G, L
- **Oilfree and greasefree**
- Safety valves are set and sealed at the factory

Connection:

1/4", 3/8", 1/2", 3/4", 1", 1 1/4", 1 1/2"

Temperature:

-200°C up to +200°C – depending on design

Set pressure:

0,2 bar – 70,0 bar– depending on design

Materials:

Component

Body	Stainless steel 1.4404 / 1.4408
Internal parts	Stainless steel 1.4404
Spring	Stainless steel 1.4310
Seal	PTFE

Lifting mechanism / Type

without lifting mechanism -> gas-tight version of spring housing (oxygen application on request)

with lifting mechanism -> non gas-tight version of spring housing (Not suitable for oxygen)

Approvals:

AD 2000 sheet A2

| DIN ISO 4126-1

| DGR 2014/68/EU

| DIN EN 13648-1

Examples of use:

- Cryogenic plant construction
- Ground freezing plants
- Dry ice blasting plants
- Liquid nitrogen dosing
- Gases used in medical equipment
- Plants for cryogenic gases which come into contact with foodstuffs

Dimensions:

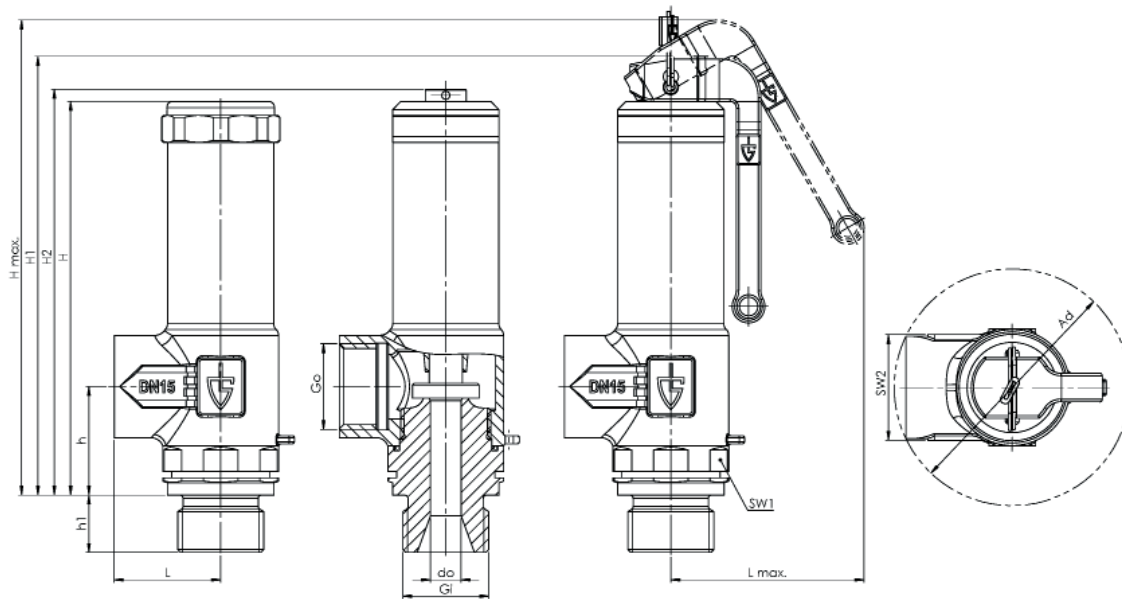

diameter DN	8	8	10	10	15	15	20	20	25	25	32	32
Inlet Gi*	1/4"	3/8"	3/8"	1/2"	1/2"	3/4"	3/4"	1"	1"	1 1/4"	1 1/4"	1 1/2"
Outlet Go*	3/8"	3/8"	1/2"	1/2"	3/4"	3/4"	1"	1"	1 1/2"	1 1/2"	2"	2"
h1	12	12	12	14	14	16	16	18	18	22	20	20
h	22	26	26	31	31	39	39	56	56	66	66	66
L	21	26	26	31	31	38	38	53	53	66	66	66
Lmax	43	47	47	66	66	86	86	85	85	122	122	122
H	82	96	96	130	130	173	173	-	-	-	-	-
H1	91	107	107	144	144	185	185	215	215	276	276	276
H2	85	99	99	134	134	172	172	203	203	264	264	264
Hmax	99	116	116	156	156	201	201	230	230	300	300	300
SW1	22	27	27	34	34	41	41	50	50	55	55	55
SW2	22	26	26	32	32	39	39	56	56	70	70	70
Ad	47	58	58	69	69	85	85	120	120	150	150	150
Do	6,0	7,5	7,5	10,5	10,5	13,0	13,0	18,0	18,0	23,0	23,0	23,0
Range of adjustment	0,2 bar – 70 bar	0,2 bar – 70 bar	0,2 bar – 70 bar	0,2 bar – 70 bar	0,2 bar – 70 bar	0,2 bar – 70 bar	0,2 bar – 70 bar	0,2 bar – 50 bar	0,2 bar – 50 bar	0,2 bar – 50 bar	0,2 bar – 50 bar	0,2 bar – 50 bar
weight kg	0,2	0,4	0,4	0,7	0,7	1,3	1,3	2,8	2,8	6,4	6,4	6,4

*Thread / Connection acc. to DIN EN ISO 228 BSP-P

Installation and Assembly:

Spring safety valves must be installed vertically to the spring cover that is located above or horizontally while taking the direction of flow into account. To guarantee perfect function of the valves, they must be mounted so that no unauthorized static, dynamic or thermal loads can take effect. If direct or indirect danger to persons or the environment may be caused by the medium discharging through the housing, suitable protective measures must be taken.

Supply

Supply connection pieces for safety valves are to be kept as short as possible and are to be designed in such a way that there can be no pressure loss greater than max. 3% of the response pressure.

Removal of condensate discharge

In the event of possible condensate formation the pipes or the valves themselves (in flanged version) must be fitted at their lowest point with a continuously operating condensate discharge device. Hazard-free removal of the condensate or medium discharge must be ensured. The body, pipes and silencers must be protected against freezing.

Blowing-off pipe / backpressure

The blow-off pipe of the safety valves must be designed to ensure that the required mass flow can be discharged pressure-free during the blowing-off process. In safety valves with metal bellows a backpressure of up to max. 4 bar has no impact on the response pressure of the safety valve.

Operation:

The operating pressure of the plant is to be least 5% lower than the closing pressure of the safety valve. In this way, the valve can satisfactorily close again after blowing off. In the event of minor leaks, which may be caused by contamination between the sealing surfaces, the valve can be made to blow off through lifting, for cleaning purposes. If this does not remove the leak, the sealing surface is probably damaged and this can only be repaired at our factory or by authorized specialists. Depending on the version, lifting is either carried out by means of a knurled nut above the spring bonnet which is turned counterclockwise (afterwards the knurled nut has to be turned back to the stop) or by actuating the lifting lever on the upper part of the valve. For delivery purposes the lifting lever is blocked by means of strap which has to be removed for actuating the lifting device.

Lifting for maintenance purposes:

In the case of safety valves with a lifting device it is recommended, and in certain plant-specific cases even stipulated that the valves from time to time must be made to blow-off by lifting the seal off the seat, in order to assure the correct functioning of the safety valve. This is why they can be made to open at the latest as from an operating pressure of $\geq 85\%$ of the response pressure. The lifting device is not to be operated when in a pressure-free state. In steam generating equipment, testing the ease of movement of safety valves must be carried out at least every 4 weeks in compliance with TRD 601. Safety valves are the ultimate safety device for the tank or system. They must be able to prevent impermissible overpressure even when all other upstream control and monitoring equipment fail. To ensure these functional characteristics safety valves require regular and recurring maintenance. The maintenance intervals are determined by the operator in dependence of the operating conditions.

Capacity table: Blowing-off rates at 10% above set pressure

Media: 1 = Air Nm³/h

2 = Water m3/h

DN	8		10		15		20		25		32	
	1	2	1	2	1	2	1	2	1	2	1	2
Set pressure bar												
0,2	11,1	0,4	17,3	0,6	33,9	1,2	51,9	1,9	99,5	3,6	162,5	5,9
0,5	17,4	0,6	27,2	0,9	53,3	1,8	81,7	2,7	156,7	5,2	255,8	8,4
1,0	25,8	0,8	40,3	1,2	79,0	2,4	121,1	3,7	232,2	7,0	379,2	11,5
1,5	34,5	1,0	54,0	1,5	105,8	2,9	162,1	4,5	310,8	8,6	507,5	14,1
2,0	43,2	1,1	67,5	1,7	132,2	3,4	202,7	5,2	388,6	10,0	634,4	16,3
2,5	51,7	1,2	80,8	1,9	158,4	3,8	242,7	5,8	465,4	11,2	759,8	18,2
3,0	60,1	1,4	93,9	2,1	184,1	4,2	282,1	6,4	540,9	12,2	883,2	20,0
3,5	68,1	1,5	106,5	2,3	208,7	4,5	319,9	6,9	613,3	13,2	1001,4	21,6
4,0	76,0	1,6	118,8	2,5	232,8	4,8	356,8	7,4	684,1	14,1	1116,9	13,1
4,5	83,8	1,7	130,9	2,6	256,5	5,1	393,2	7,8	753,8	15,0	1230,7	24,5
5,0	91,5	1,8	143,0	2,7	280,2	5,4	429,5	8,2	823,4	15,8	1344,4	25,8
5,5	99,2	1,8	155,1	2,9	303,9	5,6	465,8	8,6	893,1	16,6	1458,2	27,0
6,0	107,0	1,9	167,1	3,0	327,6	5,9	502,2	9,0	962,8	17,3	1571,9	28,3
6,5	114,7	2,0	179,2	3,1	351,3	6,1	538,5	9,4	1032,5	18,0	1685,7	29,4
7,0	122,5	2,1	191,3	3,2	375,0	6,4	574,9	9,8	1102,1	18,7	1799,5	30,5
7,5	130,2	2,2	203,4	3,4	398,7	6,6	611,2	10,1	1171,8	19,4	1913,2	32,6
8,0	137,9	2,2	215,5	3,5	422,4	6,8	647,6	10,4	1241,5	20,0	2027,0	32,6
8,5	145,7	2,3	227,6	3,6	446,2	7,0	683,9	10,7	1311,2	20,6	2140,7	33,6
9,0	153,4	2,4	239,7	3,7	469,9	7,2	720,2	11,1	1380,8	21,2	2254,5	34,6
9,5	161,2	2,4	251,8	3,8	493,6	7,4	756,6	11,4	1450,5	21,8	2368,3	35,6
10,0	168,9	2,5	263,9	3,9	517,3	7,6	792,9	11,7	1520,2	22,4	2482,0	36,5
11,0	184,4	2,6	288,1	4,1	564,7	8,0	865,6	12,2	1659,5	23,4	2709,5	38,3
12,0	199,9	2,7	312,2	4,3	612,1	8,3	938,3	12,8	1798,9	24,5	2937,1	40,0
13,0	215,4	2,8	336,5	4,4	659,5	8,7	1011,0	13,3	1938,2	25,5	3164,6	41,6
14,0	230,8	2,9	360,7	4,6	707,0	9,0	1083,7	13,8	2077,6	26,4	3392,1	43,2
15,0	246,3	3,0	384,9	4,8	754,4	9,3	1156,4	14,3	2216,9	27,4	3619,6	44,7
16,0	261,8	3,1	409,1	4,9	801,8	9,6	1229,0	14,7	2356,3	28,3	3847,1	46,2
17,0	277,3	3,2	433,3	5,1	849,2	9,9	1301,7	15,2	2495,6	29,1	4074,6	47,6
18,0	292,8	3,3	457,5	5,2	896,6	10,2	1374,4	15,6	2635,0	30,0	4302,2	49,0
19,0	308,3	3,4	481,7	5,4	944,0	10,5	1447,1	16,1	2774,3	30,8	4529,7	50,3
20,0	323,7	3,5	505,8	5,5	991,5	10,8	1519,8	16,5	2913,7	31,6	4757,2	51,6
21,0	339,2	3,6	530,0	5,6	1038,9	11,0	1592,5	16,9	3053,0	32,4	4984,7	52,9
22,0	354,7	3,7	554,2	5,8	1086,3	11,3	1665,2	17,3	3192,4	33,2	5212,2	54,1
23,0	370,2	3,8	578,4	5,9	1133,7	11,5	1737,8	17,7	3331,7	33,9	5439,8	55,4
24,0	385,7	3,8	602,6	6,0	1181,1	11,8	1810,5	18,1	3471,1	34,6	5667,3	56,6
25,0	401,2	3,9	626,8	6,1	1228,5	12,0	1883,2	18,4	3610,4	35,4	5894,8	57,7
26,0	416,6	4,0	651,0	6,3	1276,0	12,3	1955,9	18,8	3749,8	36,1	6122,3	58,9
27,0	432,1	4,1	675,2	6,4	1323,4	12,5	2028,6	19,2	3889,1	36,7	6349,8	60,0
28,0	447,6	4,2	699,4	6,5	1370,8	12,7	2101,3	19,5	4028,5	37,4	6577,3	61,1
29,0	463,1	4,2	723,6	6,6	1418,2	13,0	2174,0	19,9	4167,8	38,1	6804,9	62,2
30,0	478,6	4,3	747,8	6,7	1465,6	13,2	2246,6	20,2	4307,2	38,7	7032,4	63,2
32,0	509,5	4,4	796,2	6,9	1560,5	13,6	2392,0	20,9	4585,9	40,0	7487,4	65,3
34,0	540,5	4,6	844,5	7,2	1655,3	14,0	2537,4	21,5	4864,6	41,2	7942,4	67,3
36,0	571,5	4,7	892,9	7,4	1750,1	14,4	2682,8	22,1	5143,3	42,4	8397,5	69,3
38,0	602,4	4,8	941,3	7,6	1845,0	14,8	2828,1	22,7	5422,0	43,6	8852,5	71,2
40,0	633,4	5,0	989,7	7,8	1939,8	15,2	2973,5	23,3	5700,7	44,7	9307,6	73,0
42,0	664,4	5,1	1038,1	8,0	2034,6	15,6	3118,9	23,9	5979,4	45,8	9762,6	74,8
44,0	695,3	5,2	1086,5	8,1	2129,5	16,0	3264,2	24,5	6258,1	46,9	10217,6	76,6
46,0	726,3	5,3	1134,9	8,3	2224,3	16,3	3409,6	25,0	6536,8	48,0	10672,7	78,3
48,0	757,3	5,4	1183,2	8,5	2319,1	16,7	3555,0	25,6	6815,5	49,0	11127,7	80,0
50,0	788,2	5,6	1231,6	8,7	2414,0	17,0	3700,3	26,1	7094,2	50,0	11582,7	81,6
52,0	819,2	5,7	1280,0	8,9	2508,8	17,4	3845,7	26,6				
54,0	850,2	5,8	1328,4	9,0	2603,7	17,7	3991,1	27,1				
56,0	881,1	5,9	1376,8	9,2	2698,5	18,0	4136,5	27,6				
58,0	912,1	6,0	1425,2	9,3	2793,3	18,3	4281,8	28,1				
60,0	943,1	6,1	1473,6	9,5	2888,2	18,6	4427,2	28,6				
62,0	974,0	6,2	1521,9	9,7	2983,0	18,9	4572,6	29,0				
64,0	1005,0	6,3	1570,3	9,8	3077,8	19,2	4717,9	29,5				
66,0	1036,0	6,4	1618,7	10,0	3172,7	19,5	4863,3	30,0				
68,0	1066,9	6,5	1667,1	10,1	3267,5	19,8	5008,7	30,4				
70,0	1097,9	6,6	1715,5	10,3	3362,3	20,1	5154,1	30,9				

Article number:

Type	Lifting mechanism	Connection	Seal	Size (inlet x outlet)
SV14	0 – without (gas-tight) 1 – lever (non gas-tight)	0 – male thread	03 – PTFE	01 – 1/4" x 3/8" 02 – 3/8" x 1/2" 02.1 – 3/8" x 3/8" 03 – 1/2" x 3/4" 03.1 – 1/2" x 1/2" 04 – 3/4" x 1" 04.1 – 3/4" x 3/4" 05 – 1" x 1 1/2" 05.1 – 1" x 1" 06 – 1 1/4" x 1 1/2" 06.1 – 1 1/4" x 2" 07 – 1 1/2" x 2"

Example no. SV14100302:

SV14 | **1** | **0** | **03** | **02**

Article number: SV14100302

Cryo safety valve made of stainless steel

Internal parts stainless steel

Lifting mechanism: lever

Connection: male thread

Seal: PTFE

Size: Inlet: 3/8" x Outlet: 1/2"

Image similar, subject change without notice.